

## Control Systems in Bobov Dol TPP

The design and the putting into operation of the Control Systems in Bobov Dol TPP and their functions was carried out by Start Engineering JS Co., branch Automation specialists with the collaboration of AMEES Ltd. and the University of Chemistry and Metallurgy - Sofia.

The implementation of I&C microprocessor systems in Bobov Dol TPP began in 1995 with the putting into operation of the Bulgarian system МИК 4000 Се for the control of Unit 3.

The system architecture is shown on figure 1.

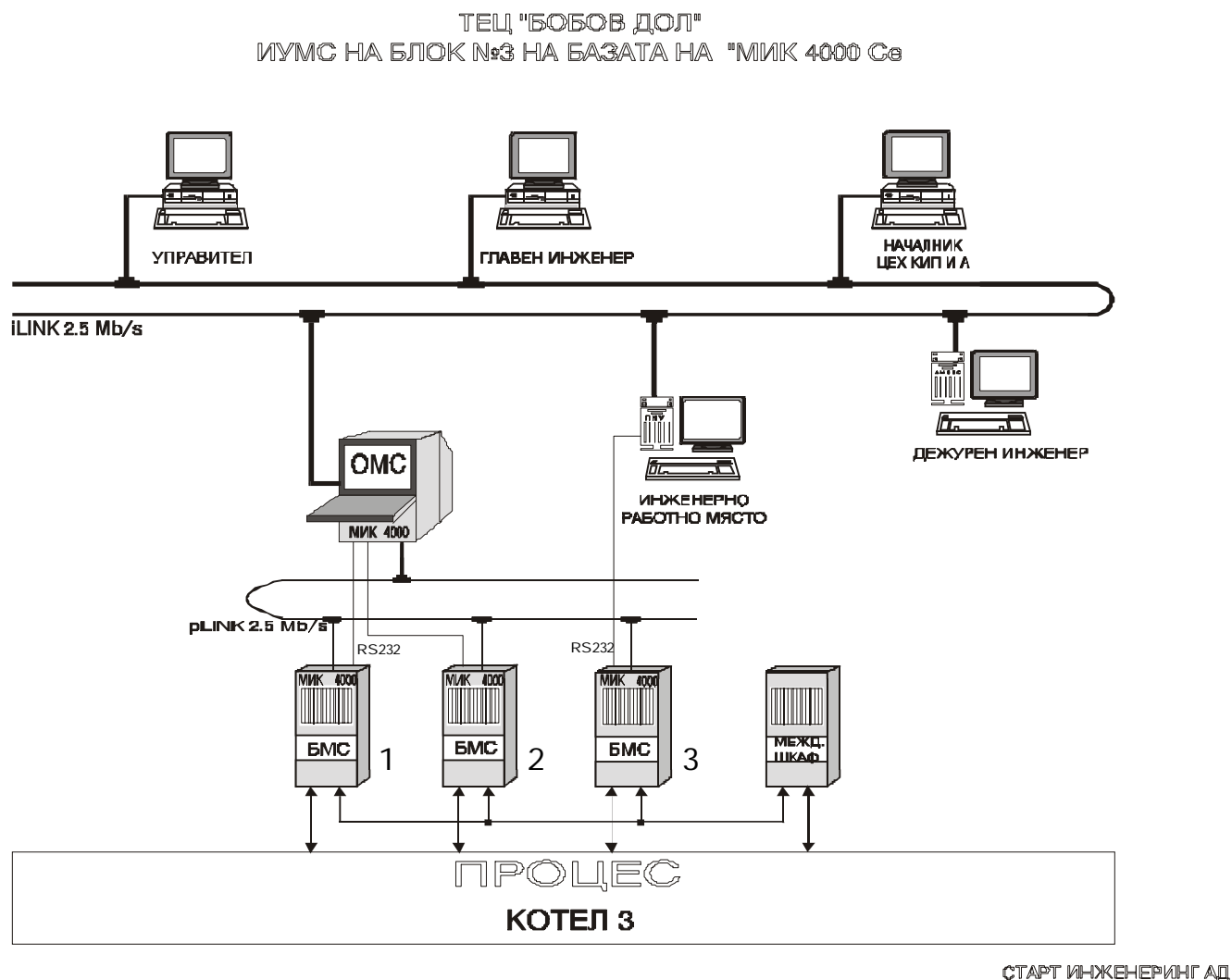

Figure 1. System architecture of Unit 3 in Bobov Dol TPP

The following systems for automatic control were foreseen for the system:

1. Electrical power;
2. Pressure before the turbine;
3. Common air flow with a correction of the oxygen in the fume gases;
4. Thin out in the furnace's chamber;
5. Drum level;
6. Total outlay of coal;
7. Outlay of coal of the individual Dust Preparation System;

8. Temperatures of the primary steam;
9. Temperatures of the secondary steam.

Because of the lack of steering equipment for the fume ventilators the system for automatic regulation “Thinning out in the furnace’s chamber” was not put into operation.

An attempt for holding up the thinning out, the quantity of the secondary air and the temperature of the outgoing fume gases with the steering equipment of the air ventilators, but this led to an entrance into the limited flow of coal and electrical power respectively.

The first realized diagram for control of the electrical power and the heat load of the boiler was a leading boiler. Because of the specific burning of the coal in Bobov Dol TPP – high varying calorificity, humidity and ash content, this diagram was not appropriate.

After profound analyses and simulation research, was achieved the actual working coordinated diagram of the three units for control on the basis of the leading turbine.

Under the leadership of Prof. M. Hadjiiski was developed a program for calculation of the efficiency of the boiler aggregate, the calorificity of the burned coal, the ventilation properties of the separate Dust Preparation System, on the basis of which is defined the position of the torch in the furnace chamber, as well as the quantity of the gases before the fume ventilators.

The developed information mnemonic is shown on figure 2.

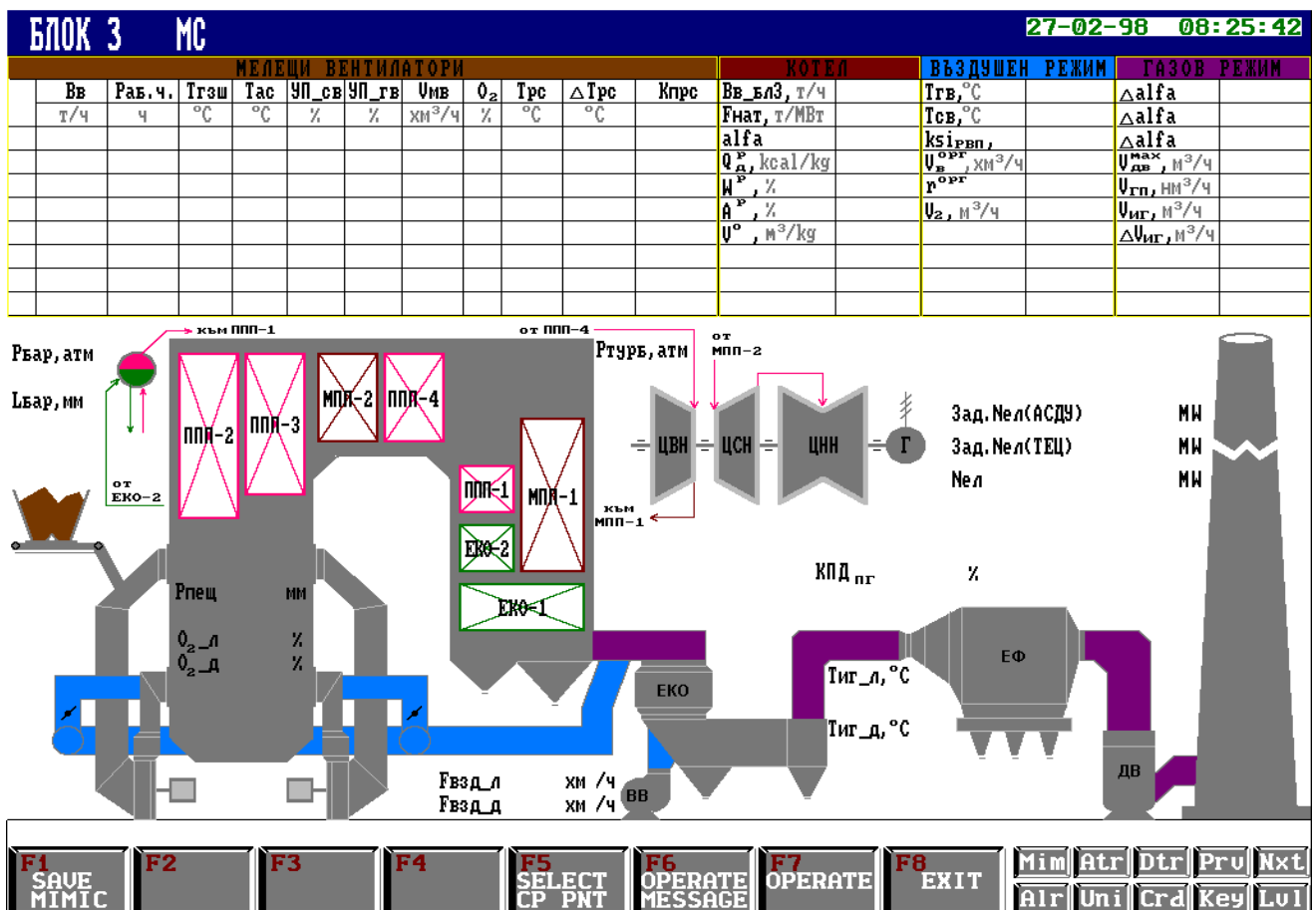

Figure 2

In 1998 an additional operational station and two additional base stations with I/O modules, connected by CAN BUS, were delivered. The extension made possible the temperature control of the turbine. There were also realized visualization functions of the start curves of the turbine for different states of start up.

In 2000 between NEK and HONEYWELL Bulgaria was signed a contract for the delivery of Systems for control of Units 1 and 2 of Bobov Dol TPP. Start Engineering JS Co. dealt with the design of part I&C, the algorithms for functional group controls, the systems for control, the start up and the commissioning of the system. The systems for turbine control SIMADYN D were delivered from SIEMENS, which were put into operation by specialists from Start Engineering and AMEES Radnevo.

For the first time in Bulgaria, the control of all the equipment of a 210 MW power unit was handled by the systems, without any panels and decks for control.

The base shield was remade for less than six months, unit 1 and then unit 2 were put into operation. The control of the process, the starting up and the stopping of equipment and aggregates are made from the screens of the operator stations. The erected network provides information about the process in all production departments as Technological, I&C, etc. A WEB Server is provided, offering the possibility for supervision of the boiler aggregates through Internet.

Some basic mnemonics are shown on the following figures.

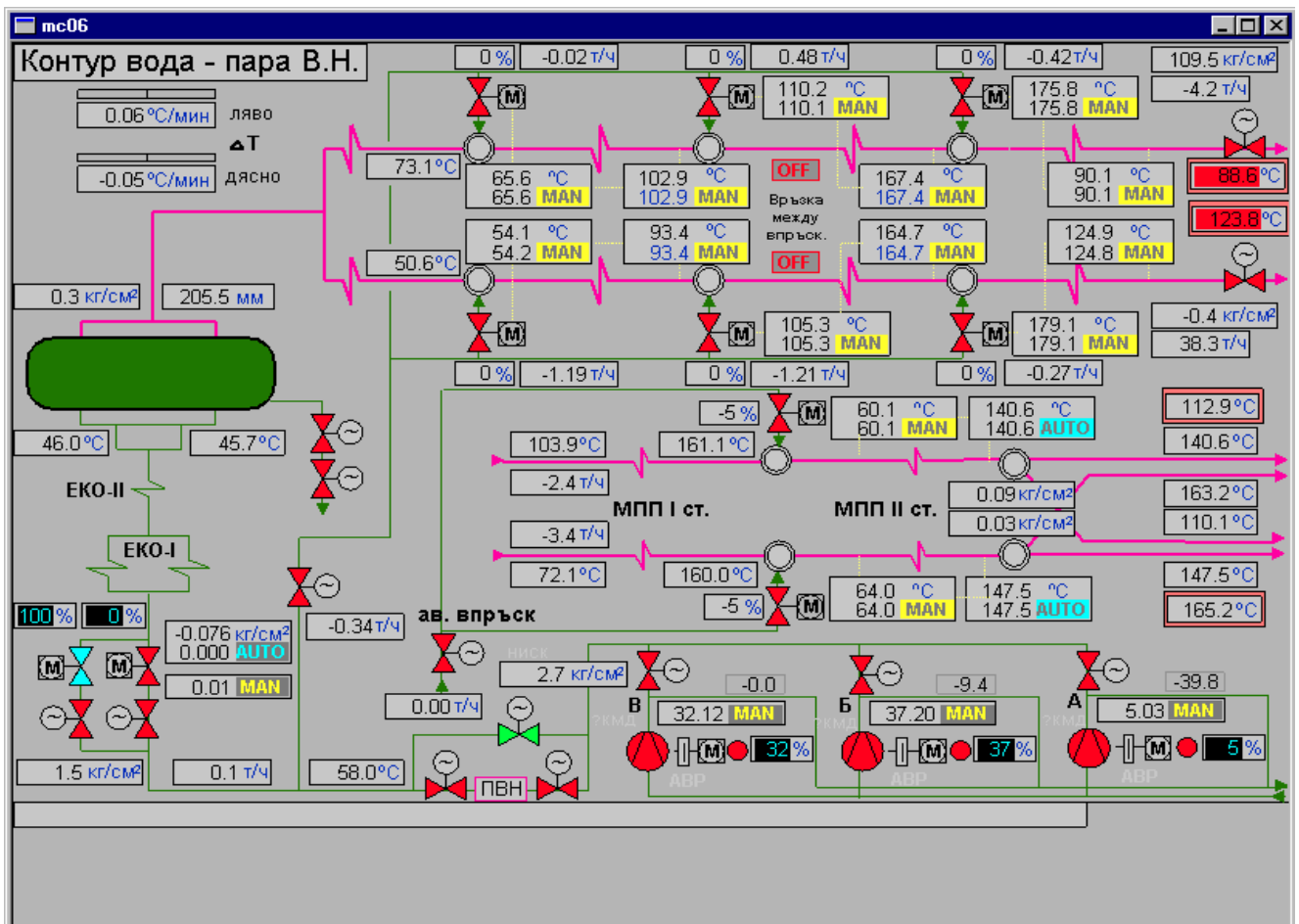

Figure 3. Steam tract

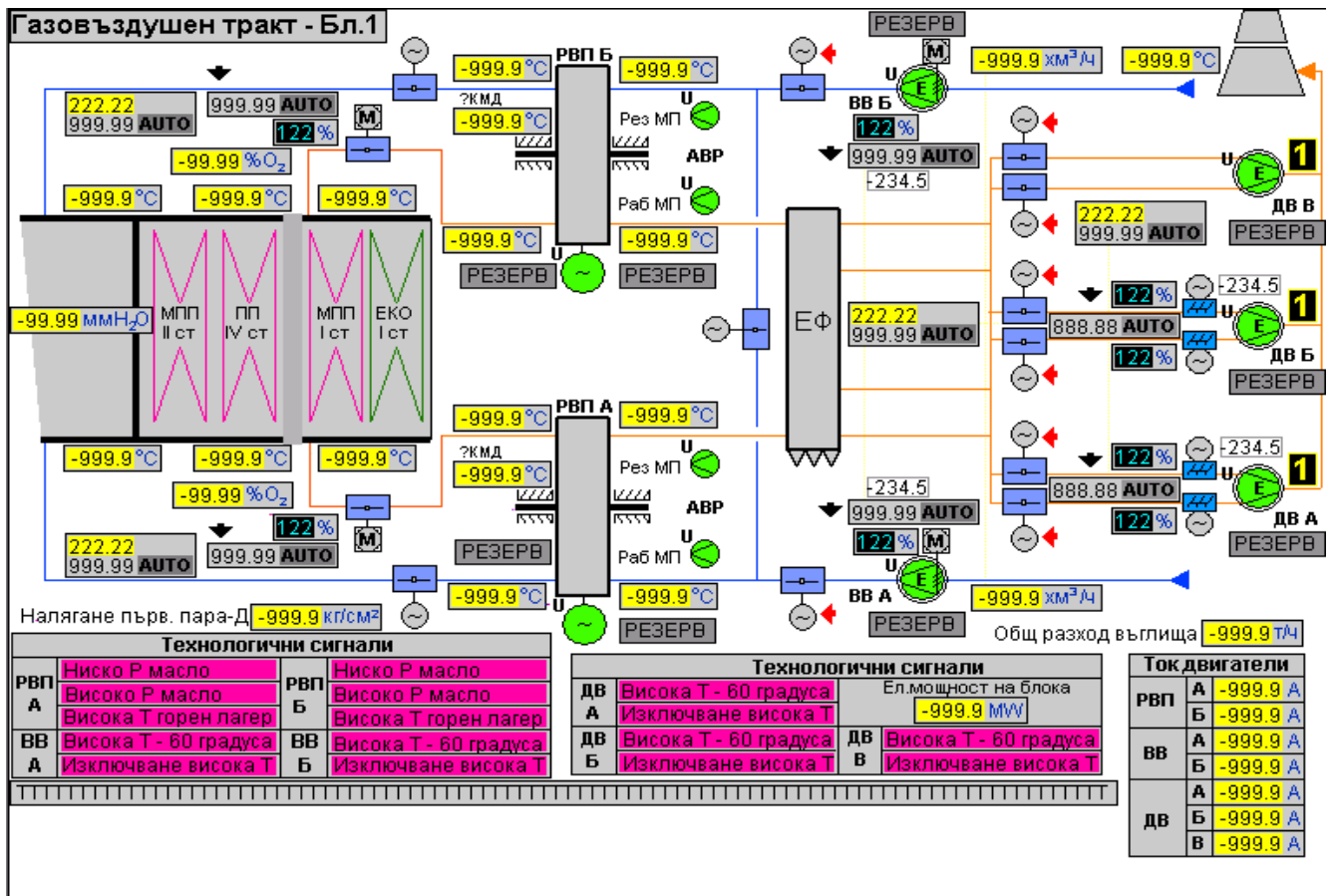

Figure 4. Gas-air tract

A communication between SIMADYN and TPS with complete integration of the two systems was realized. Actually, the three units of Bobov Dol TPP are working with a dispatch control, as 1 and 2 are participating in the primary regulation.

On figures 5a and 5b are shown pictures of the Base shield for control №1 before and after the reconstruction.

In 2002 there is a project for the delivery of a new System for control (Honeywell) of unit 3 of Bobov Dol TPP that is coming, which will replace the existing (MIK 4000 Ce), as a final stage of the complete modernization of the plant. The architecture of the System for control, after completion of the project will have the looks, shown on figure 6.

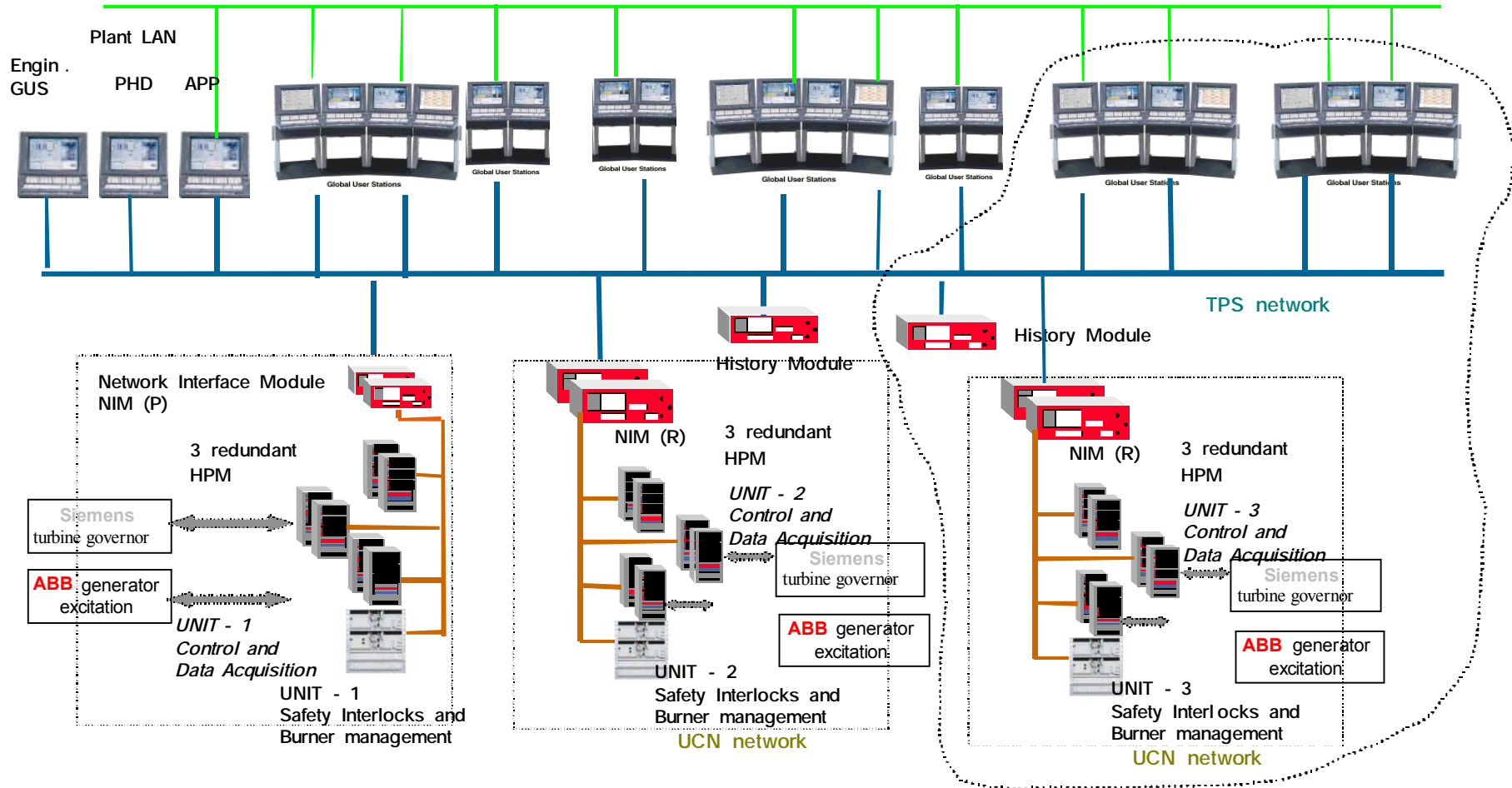

Figure 5a. Base shield for control 1 before the reconstruction



Figure 5b. Base shield for control 1 after the reconstruction

## Configuration of the System for control of Bobov Dol TP



**Honeywell**

С разрешението на HONEYWELL - България